

- High quality thermal transfer printing for high resolution bar codes and text
- Available in a variety of application modules
- Multiple label configuration menu and flight time compensation for label placement control

Videojet® P3400

Label Printer Applicator





The Most Advanced System for Automatic Print & Apply Labeling

The Videojet P3400 label printer applicator is easy to use and maintain, and features the versatility of modular spares to deliver maximum uptime and performance. Available with multiple printer options and a variety of application choices, the Videojet P3400 provides a customizable, off the shelf solution.

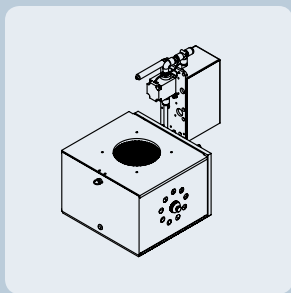

Air Jet Module

A vacuum box is used to hold the printed label until the product is in the application position. The air jets are used to blow the label onto the target product, providing a non-contact method of applying labels at high speed.

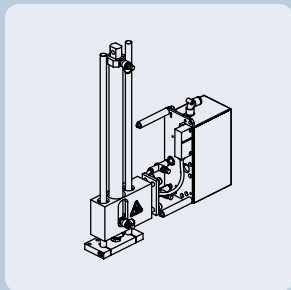

Basic Tamp Module

In this low cost Basic Tamp assembly, a vacuum pad is used to hold the printed label until the product is in the application position. The tamp pad is moved from the home position by an air cylinder until the tamp pad touches the product, applying the label. Available in 2-inch, 6-inch and 12-inch (50, 160, and 300 mm) lengths.

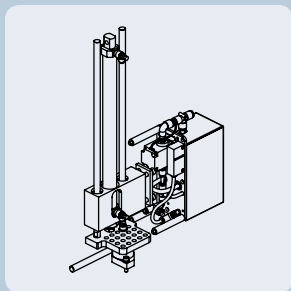

Tamp Jet Module

The Tamp Jet module works the same as the standard tamp, but has the added benefit of blowing the label onto the product and a standard airsave feature, ensuring lower operating costs.

Videojet P3400
Label Printer Applicator

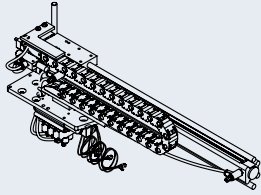

Heavy Duty Tamp Module

Ideally suited for pallet applications or variable height products where the product height variation is greater than 12 inches (300 mm), the heavy duty tamp module is available in 20 and 32 inch lengths (500 and 800 mm).

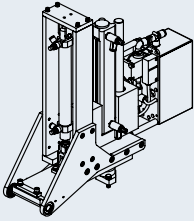

Two Panel/Two Label Module

This module combines the standard tamp with a swing arm module to apply two labels on adjacent sides of the target product.

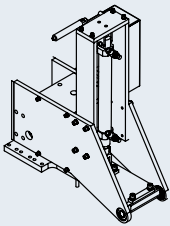

Swing Arm Module

The Swing Arm module is designed to apply labels to either the leading or trailing edge of the target product. The application method is similar to tamp, however instead of a linear movement from the air cylinder, the arm is moved on a pivot to apply the label 90 degrees from the conveyor line. Maximum reach is 12 inches (300 mm).

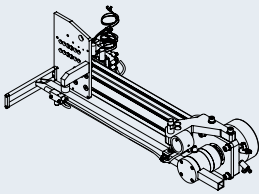

Heavy Duty Swing Arm Module

This module operates the same as the standard swing arm. Designed to be adjusted between 12 inches (300 mm) and 24 inches (600 mm), it is ideally suited for pallet labeling applications.

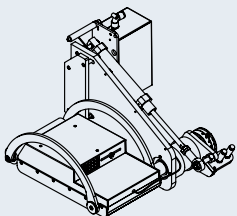

Corner Wrap Module

This application module is designed to apply around the leading corner of the target product and has an integrated secondary roller, ensuring full adhesion around the corner and side of the product. Minimum label size is 2 x 6 inches (50 mm x 154 mm) and maximum size is 6 x 12 inches (154 mm x 300 mm).

	Label Width		Label Length		Stroke/Reach
	Min	Max	Min	Max	
Airjet	1.0 in. 25 mm	7.1 in. 180 mm	1.0 in. 25 mm	9.2 in. 230 mm	
Tamp	1.0 in. 25 mm	7.1 in. 180 mm	1.0 in. 25 mm	14.2 in. 360 mm	2.0, 6.4, 12.0 in. 50, 160, 300 mm
Tampjet	2.4 in. 60 mm	7.3 in. 185 mm	4.0 in. 100 mm	8.2 in. 210 mm	2.0, 6.4, 12.0 in. 50, 160, 300 mm
Heavy Duty Tampjet	1.0 in. 25 mm	7.1 in. 180 mm	1.0 in. 25 mm	9.1 in. 230 mm	20.0, 32.0 in. 500, 800 mm
Two Panel Two Label	1.0 in. 25 mm	7.1 in. 180 mm	1.0 in. 25 mm	9.8 in. 250 mm	4.0 in. / 12.0 in. 100 / 300 mm
Swing Arm	1.0 in. 25 mm	7.1 in. 180 mm	1.0 in. 25 mm	9.8 in. 250 mm	12.0 in. 300 mm
Heavy Duty Swing Arm	2.4 in. 60 mm	7.3 in. 18 mm	4.0 in. 100 mm	8.2 in. 210 mm	12.0 - 24.0 in. 300 - 600 mm
Corner Wrap	3.0 in. 75 mm	6.2 in. 154 mm	6.2 in. 154 mm	12.0 in. 300 mm	

Dimensions

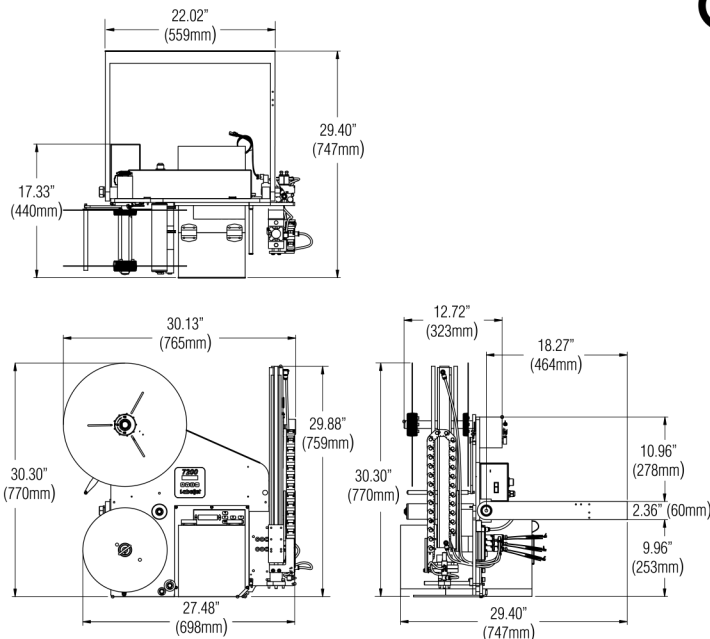

Standard Features

- Compatible with Sato, Zebra, Datamax, Novex OEM thermal transfer and RFID print engines
- User configurable inputs and outputs
- Multiple label configuration memory
- Optical low label sensor
- Ethernet connectivity for set-up, control and status monitoring
- Automatic label placement control for variable height products
- Shaft encoder input for variable speed conveyors

Options

- A complete range of application modules to meet all your labeling requirements
- Label on pad sensor
- Low pressure sensor
- Tamp home sensor
- Tamp extended sensor
- 16" (400 mm) Unwind

Electrical Requirements

115/220/240 Vac 50/60Hz single phase at up to 300W max.

Weight

Approx. 77.4 lbs. (35 kg), dependent on machine configuration

Compressed Air

Clean, dry air at 5.6 bar consumption between 5.3 to 127.2 quarts per minute (5 liters to 120 liters/min.), dependent upon application method and rate

Interfaces

Ethernet, RS 232, parallel USB wireless options available

Approvals



+622158303560
www.markindo.co.id / info@markindo.co.id

Videojet Technologies Inc.
PT. Markindo Rekateknik
Graha Arteri Mas 2, Jl Panjang No 68, Kav 6
Jakarta Barat, DKI Jakarta