



Print & Apply Labeler with Intelligent Motion™

Videojet® 9550 with Tamp Applicator

The Videojet 9550 with Tamp Applicator is a smarter print and apply labeler that targets zero unscheduled downtime and reduces costs and errors in case coding operations.

Intelligent Motion™ Technology automatically and precisely controls the entire system helping to remove operational downtime often caused by label jams and snapped labels. A robust and simply designed applicator makes it easy to use, plus an integrated pack detect feature helps ensure accurate label placement.

The 9550 with Tamp Applicator is ideal for top-of-pack labeling onto variable height cases, bundles or shrink wrapped products or for applications when the pack is stationary at the point of labeling.

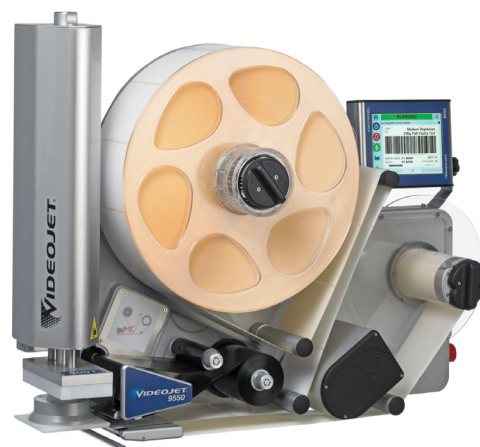

Uptime Advantage

- Optimize maintenance labor by removing common wear and adjustment parts
- Integrated pack/case detect and applicator home/extended sensors fitted as standard
- Intelligent Motion™ precisely controls label feed with no clutches and no nip roller

Built-in productivity

- Optimize print quality and printhead life with automatic printhead pressure regulation
- Track performance and help achieve OEE improvements with on-screen diagnostics
- 53mm and 107mm printhead versions for optimum performance on a wide range of label sizes

Code Assurance

- Virtually eliminate operator errors, helping to ensure products are coded correctly with built-in Code Assurance software features
- Minimize operator touches with on-board label database for accurate job selection
- Automate bar code creation by linking data from multiple text fields

Simple usability

- Perform label and ribbon changes in less than 60 seconds through simplest web path
- Quickly check status and select jobs with single, intuitive interface that makes operation easy
- Easy access via pivot to applicator and air-pipe (tool-free access) for printhead cleaning and maintenance

Videojet® 9550 with Tamp Applicator

Print & Apply Labeler with Intelligent Motion™

Application method

Pneumatic telescopic tamp applicator
Stroke/Reach 11.8" (300mm) (variable - automatic pack/case detection)

Print technology

Thermal Transfer printing with Intelligent Motion™ Ribbon Drive and Direct Thermal
53mm and 107mm printhead versions

Print resolution

300dpi / 200dpi emulation mode

Printhead health monitoring

Tool-free quick release printhead replacement

Print speed

1.6 – 19.7inches/sec (40 – 500mm/sec)

Throughput

Up to 60 packs per minute (depending on label size, telescopic stroke)
Recommended max conveyor speed 98.4ft/min (30m/min)

Ribbon specification

Width: 2.2" (55mm), 3.0" (76mm) and 5.9" (150mm) (standard)
Capacity: Up to 830 m, including automatic ribbon save (< 1mm ribbon gap between successive prints irrespective of label size or speed)
Low Ribbon and End of Ribbon detection with predicted changeover time built in as standard

Label specification

Label Width 2.0" to 4.5" (50mm to 115mm)
Label Length 2.0" to 5.9" (50mm to 150mm)
Capacity: Up to 400mm spool diameter (typically delivers over 9000 typical GS1 bar code labels per roll)
Low Labels and End of Label Reel detection, with predicted changeover time built in as standard
Automatic adjustment for label/backing type and label size 400MB on-board label database, sufficient for 25,000 typical GS1 bar code label design

Tamp sizes

116mm x 110mm (standard)
110mm x 150mm (optional accessory)

Print capabilities

Full downloadable font support using TrueType® fonts (including multiple languages and Unicode support); fixed, variable and merged text fields; flexible date/time formats; flexible shift code formats; auto best before date calculations and concession management; calendar rules; auto incrementing decrementing text, counters and bar codes; multiple graphic formats supported (up to maximum print area); link fields to databases; scalable text and text blocks

Bar codes supported

EAN 8, EAN 13, UPC-A, UPC-E, Code 39, GS1-128, Code 128, ITF, RSS (including 2D composite codes); others available upon request

Connectivity

Ethernet, Power-over-Ethernet, RS232, Configurable I/O (24V, PNP and volt free)
USB (for backup/restore and label upload), remote Control Videojet 9550 via a web browser

Communications protocols

Compatible with Videojet Clarisuite™
Videojet binary and simple-ASCII protocols
Compatible with any label design software which supports Zebra or Sato print engines
Zebra (ZPL), Sato (SBPL) and Markem-Imaje (Cimcomms) protocol support

Interface

CLARiTY™ Controller with Interactive on-board video tutorials

Language capabilities

Arabic, Bulgarian, Czech, Danish, English, German, Greek, Finnish, French, Hebrew, Hungarian, Italian, Japanese, Korean, Dutch, Norwegian, Polish, Portuguese, Romanian, Russian, Serbian, simplified Chinese, Slovak, Spanish, Swedish, Thai, Turkish, Traditional Chinese, Vietnamese

Compressed air

6 Bar. 90psi, uncontaminated

Power consumption

90-260VAC (115W at 50 packs per minute)

Operating environment

Temperature Range: 41-104°F (5-40°C)
Humidity: 20-85% Relative, non-condensing

Weight

105.8lbs (48kg) (max, including ribbon and labels)

Applicable certifications

CE, TÜV

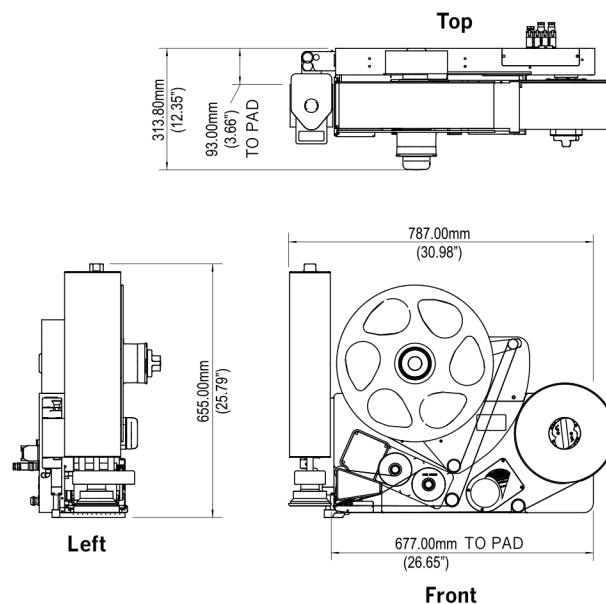

Call **+622158303560**
Email **info@markindo.co.id**
or visit **www.markindo.co.id**

Videojet Technologies Inc.
PT. Markindo Rekateknik
Graha Arteri Mas 2,
Jl Panjang No 68, Kav 6
Jakarta Barat, DKI Jakarta

© 2016 Videojet Technologies Inc. — All rights reserved.

Videojet Technologies Inc.'s policy is one of continued product improvement. We reserve the right to alter design and/or specifications without notice. TrueType is a registered trademark of Apple Computer, Inc.

Part No. SL000595
ss-9550-tamp-en-sg-0916

