



Print & Apply Labeler with Intelligent Motion™ technology

## Videojet® 9550 Corner Wrap

The Videojet 9550 Corner Wrap is a smarter print and apply labeler that is designed to target zero unscheduled downtime and can help reduce costs and errors in case coding operations.

Our Intelligent Motion™ technology automatically and precisely controls the entire system, helping to remove operational downtime often caused by label jams and snagged labels. A robust and simply designed applicator makes it easy to use, plus an integrated pack detect feature helps ensure accurate label placement.

The 9550 with Corner Wrap applicator is ideal for cases or shrink wrapped products where the label must be applied across adjacent panels so that label information can be seen in various orientations.



### Uptime Advantage

- Patented Direct Apply™ technology uses simple, single roller wipe action to wrap case corners, removing unnecessary complexity and time from the process
- Optimize maintenance labor by removing common wear and adjustment parts
- Built in pack/case detect sensor eliminates the need for additional components, simplifying integration and set-up
- Clean, robust design helps protect components during operation

### Built-in productivity

- Optimize print quality and printhead life with automatic printhead pressure regulation
- On-screen diagnostics help achieve OEE improvements
- Single roller wipe design eliminates applicator arm that can damage cases and cause equipment wear, as well as on-going adjustments, service and downtime

### Code Assurance

- Virtually eliminate operator errors, helping to ensure products are coded correctly with built-in Code Assurance software features
- Minimize operator touches with on-board label database for accurate job selection
- Automate bar code creation by linking data from multiple text fields

### Simple usability

- Perform label and ribbon changes in less than 60 seconds through simplest web path
- Quickly check status and select jobs with a single, intuitive interface that makes operation easy

# Videojet® 9550 Corner Wrap

Print & Apply Labeler with Intelligent Motion™ technology

## Application method

Direct Apply™ technology for side panel, pneumatic roller wipe for rear panel

## Print technology

Thermal transfer printing with Intelligent Motion™ Ribbon Drive and Direct Thermal 53mm and 107mm printhead versions

## Print resolution

300dpi / 200dpi emulation mode

## Printhead health monitoring

Tool-free quick release printhead replacement

## Print speed

1.6 – 19.7inches/sec (40 – 500mm/sec)

## Throughput

Up to 48 packs per minute (depending on label size)  
Recommended max conveyor speed 98.4ft/min (30m/min)

## Ribbon specification

Width: 2.2" (55mm), 3.0" (76mm) and 4.3" (110mm)  
Capacity: Up to 830m, including automatic ribbon save (<1mm ribbon gap between successive prints irrespective of label size or speed)  
Low Ribbon/End of Ribbon detection with predicted changeover time built in as standard

## Label specification

Label Width 1.6" to 4.5" (40mm to 115mm)  
Label Length 2.0" to 11.8" (50mm to 300mm)  
Capacity: Up to 400mm spool diameter (typically delivers over 9000 typical GS1 bar code labels per roll)  
Low Labels and End of Label Reel detection, with predicted changeover time built in as standard Automatic adjustment for label/backing type and label size 400MB on-board label database, sufficient for 25,000 typical GS1 bar code label design

## Print capabilities

Full downloadable font support using TrueType® fonts (including multiple languages and Unicode support); fixed, variable and merged text fields; flexible date/time formats; flexible shift code formats; auto best before date calculations and concession management; calendar rules; auto incrementing decrementing text, counters and bar codes; multiple graphic formats supported (up to maximum print area); link fields to databases; scalable text and text blocks

## Bar codes supported

EAN 8, EAN 13, UPC-A, UPC-E, Code 39, GS1-128, Code 128, ITF, RSS (including 2D composite codes); others available upon request

## Connectivity

Ethernet, Power-over-Ethernet, RS232, Configurable I/O (24V, PNP and volt free)  
USB (backup/restore and label upload), remote control Videojet 9550 via a web browser

## Communications Protocols

Compatible with Videojet CLARISUITE™  
Videojet binary and simple-ASCII protocols  
Compatible with any label design software which supports Zebra or Sato print engines  
Zebra (ZPL), Sato (SBPL) and Markem-Imaje (Cimcomms) protocol support

## Interface

CLARITY™ Controller with Interactive on-board video tutorials

## Language Capabilities

Arabic, Bulgarian, Czech, Danish, English, German, Greek, Finnish, French, Hebrew, Hungarian, Italian, Japanese, Korean, Dutch, Norwegian, Polish, Portuguese, Romanian, Russian, Serbian, simplified Chinese, Slovak, Spanish, Swedish, Thai, Turkish, Traditional Chinese, Vietnamese

## Compressed Air

6 Bar. 90psi, uncontaminated

## Power Consumption

90-260 VAC (115W at 50 packs per minute)

## Operating Environment

Temperature Range: 41-104°F (5-40°C)  
Humidity: 20-85% Relative, non-condensing

## Weight

Complete system – 103.39lbs (47kg)  
Corner Wrap applicator – 15.20lbs (7kg)  
9550 with labels and ribbon – max 88.19lbs (40kg)

## Applicable certifications

CE, TÜV

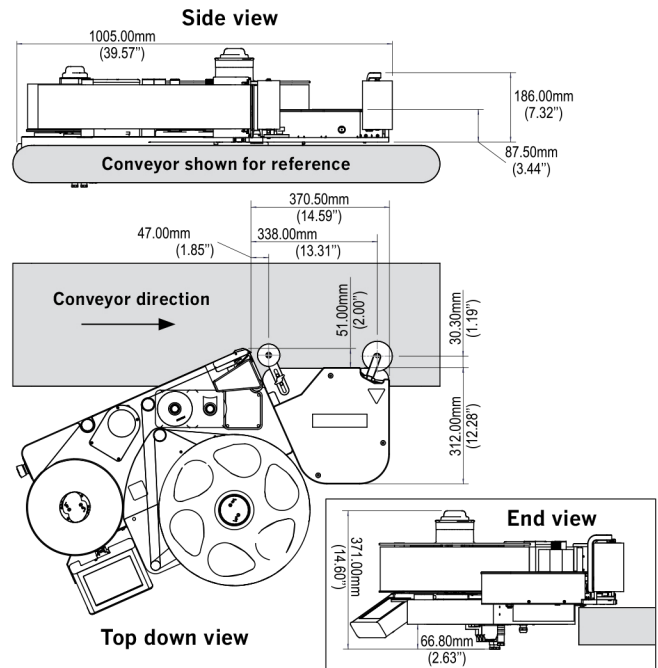

Call **+622158303560**  
Email **info@markindo.co.id**  
or visit **www.markindo.co.id**

Videojet Technologies Inc.  
PT. Markindo Rekatetik  
Graha Arteri Mas 2,  
Jl Panjang No 68, Kav 6  
Jakarta Barat, DKI Jakarta

© 2016 Videojet Technologies Inc. — All rights reserved.

Videojet Technologies Inc.'s policy is one of continued product improvement. We reserve the right to alter design and/or specifications without notice. TrueType is a registered trademark of Apple Computer, Inc.

Part No. SL000623  
ss-9550-corner-wrap-en-sg-0916

