

tem

A dependable solution of Powder Product Packaging

**MADE IN
JAPAN
QUALITY**

FRJB

Auger Filling Machine



*The photo is an image of FRJB (Auger Filling Machine) combined with TWJB (VFFS machine)

Auger filling machine for cost conscious + quality conscious customers built on our long time experience for powder filling.

The combination with our VFFS provides you with an easy operation from one touch panel.

With Tokyo Automatic Machinery's long history for powder filling technology, the new Auger Filling Machine FRJB combined with our VFFS model TWJB will be the best cost-performance ratio as Made in Japan.

1 A New Auger Overload Detection.

A new equipped program calculates the overload and position deviation of Auger. This achieves higher accuracy of overload deviation.

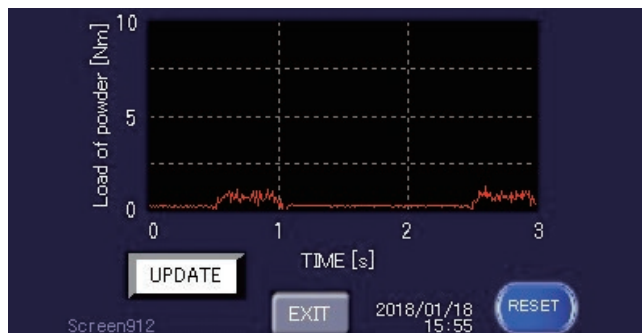

2 Single controller Operation.

Both Filling machine and VFFS machine can be operated by one controller.



3 Long Auger and Short Auger.

Depending on the nature of powder we offer the best Auger screw.

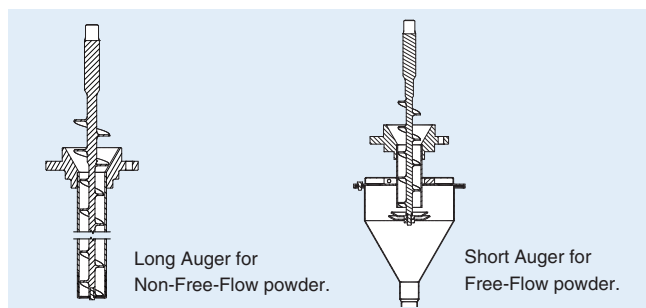

FRJB Machine Specifications

Filling Speed	1 ~ 70 fillings/min
Filling weight range	5 ~ 2,000g
Hopper Capacity / Weight	40ℓ 5.1kg
Power Supply	3 phase 200V 50/60 Hz approx 7.1kVA
Machine Weight	180kg

External Dimensions (mm)

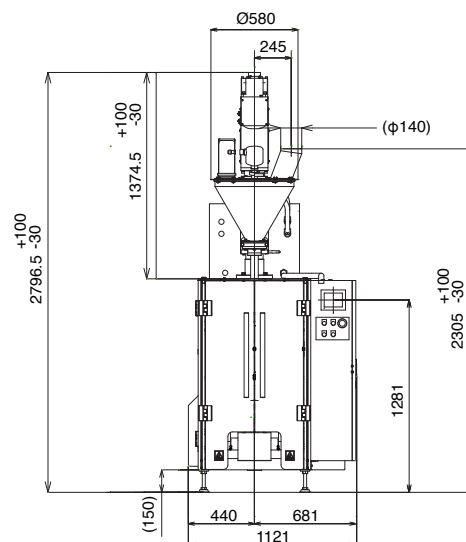
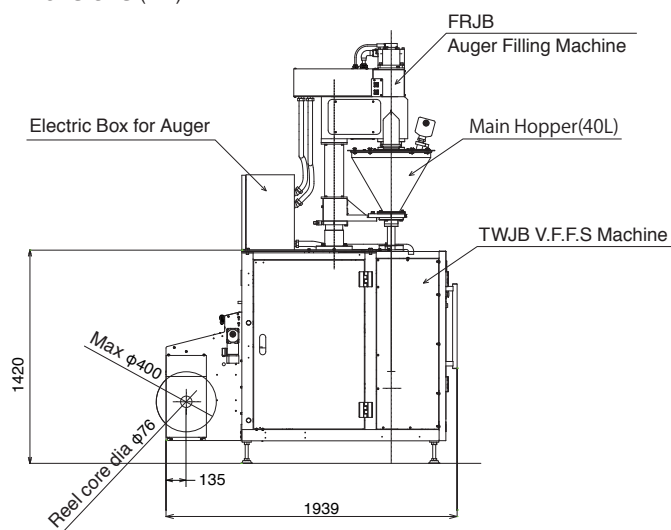

Specifications are subject to change without notice due to technical improvements or modifications.

Tokyo Automatic Machinery Works, Ltd.

TOJIKI BLDG., 3-10-7 Iwamotocho, Chiyoda-Ku, Tokyo 101-0032 Japan
 TEL: 81-3-3866-4824 FAX: 81-3-3866-7150
 URL: <http://www.tam-tokyo.co.jp/>
 E-mail: tam-overseas@tam-tokyo.co.jp

Agent: